

Polaris 380 Factory Rebuild Kit

Tools Needed:

- Phillips screwdriver
- Needle nose pliers
- Small flathead screwdriver

Disassembly

1. Remove and discard the all-purpose bag, head float, top cover(s), feed pipe/timer blank assembly and sweep hose assembly.
2. Remove the four screws that secure the frame to the base. Lift the frame off the base at a 45-degree angle, pull back and lift off. Discard the base. The rebuild kit contains a pre-assembled base unit, so all items still attached to the base can be discarded.
3. Familiarize yourself with the gears, bearings and e-clips, and note their location on the shafts before dismantling the frame (see diagram below). Disengage the front and rear belts by pushing the belt off the pulley while turning the wheel.
4. Remove the hub caps, e-clips, wheels, belts, axle blocks, transfer pulley/drive shaft assembly, gears, bearings and turbine wheel. These parts can be discarded.

5. If the frame has not already been notched, file the frame to provide proper clearance for the feed pipe/timer blank assembly.

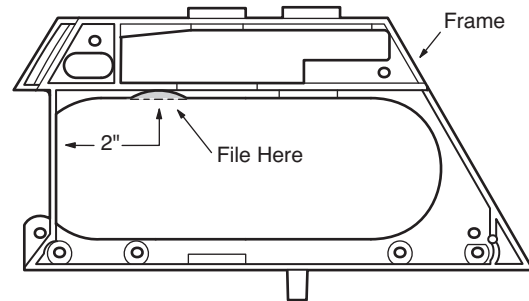

Assembly

1. Install the new axle blocks using lock washers with screws. Tighten screws loosely to keep them in place.

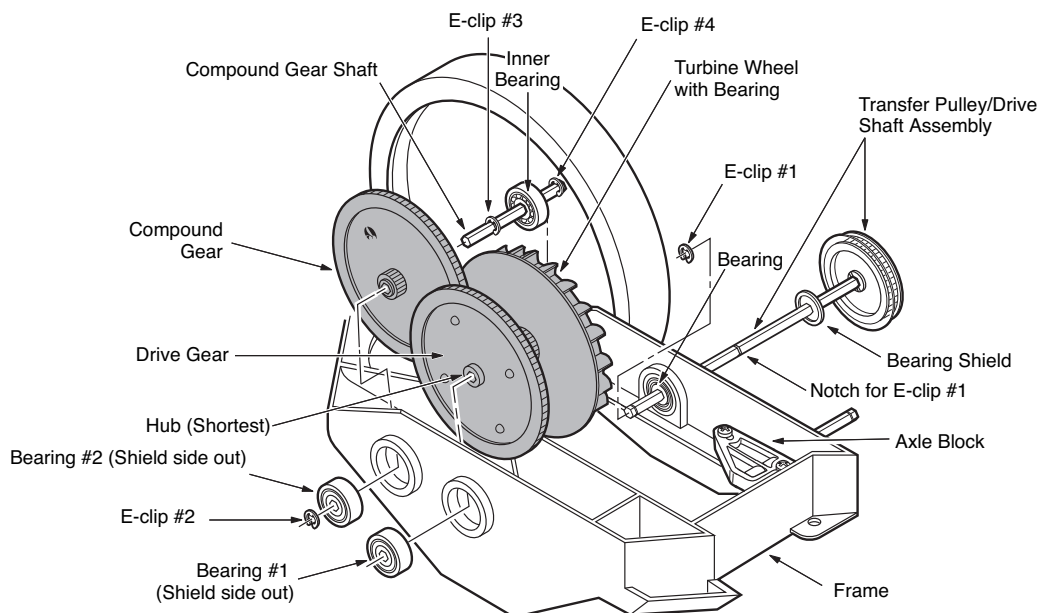
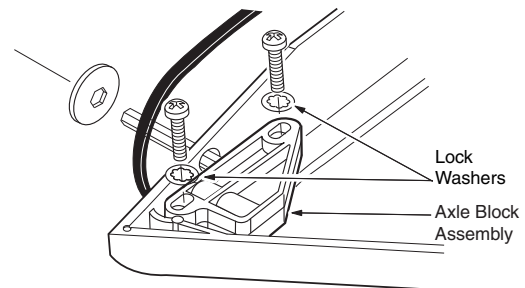

- Install bearings, shield side out. Insert compound gear shaft with inner bearing. Install new compound gear. **Note: Gear may seem tight.**
- Once gear is installed attach e-clip. Push the compound gear shaft through, secure it to the other side with another e-clip. E-clips should snap into place.
- Place the longest hub of the new drive gear into the new turbine wheel.
- Push the drive shaft through the new turbine bearing, turbine wheel, drive gear and install single-wheel side wheel with bearing. Secure with e-clip.
- Lay the frame on the single-wheel side and place the drive belts over the axle block shafts. Install the new bearing shields.
- Install the new double-wheel side wheels with bearings, e-clips and the hub caps. Engage each belt by pushing the belt onto the pulley while turning the wheel. The small belt should be on the inside of the transfer pulley and the large belt on the outside with the belt divider separating them.
- Place the frame on the double-wheel side. Push the axle blocks toward the outside edge of the Polaris until the belts have 1/4" tension and tighten the axle block screws.

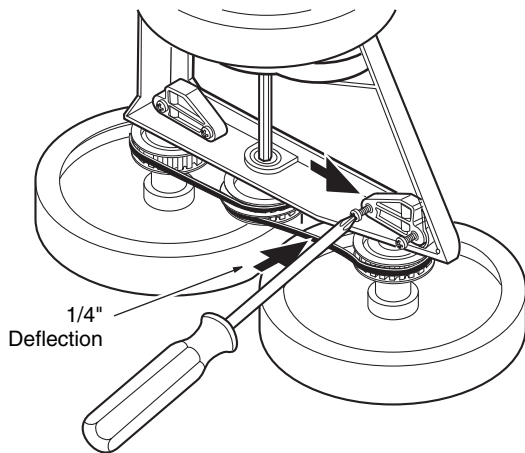

- Remove two back screws from new pre-assembled new body. Lift off back plate. Push in vacuum tube latch to remove top.
- Place lower turbine housing into base. Place new base weight on rear jet retainer flush against the vacuum tube.
- Slide frame onto new base. Reinstall three of the 3/4" screws into frame. Place upper turbine housing cover on, then screw in the fourth and final 3/4" screw.

- Install feed pipe and o-ring. Reinstall the three feed pipe screws.

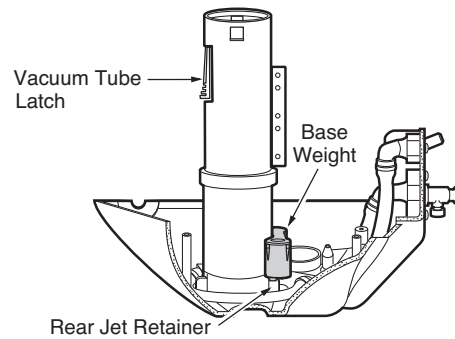

- From the back, slide top in and over vacuum tube. Align top and base and snap into place. **IMPORTANT: Top should be secured by the vacuum tube latch.**
- Slide on back plate and reinstall screws to secure the thrust jet. You may have to create tension on the thrust jet to line up the holes.
- Attach new head float. pushing it forward as close to the Polaris as possible.
- Attach the new bag.
- Attach sweep hose using the new attachment clamp.

Replacement of In-line Back-up Valve

- Remove any existing in-line back-up valve. The replacement Polaris in-line back-up valve and float should be installed 30" from the cleaner.
- Install the new float as shown below. It may be helpful to trim the end of the hose at an angle so the hose can be pulled through the float with needle nose pliers. Once the float is installed, trim the hose square.

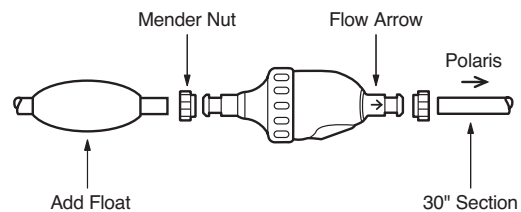

- Attach the back-up valve to the hose with the flow arrow pointing toward the cleaner.
- Push the new float as close to the back-up valve as possible.

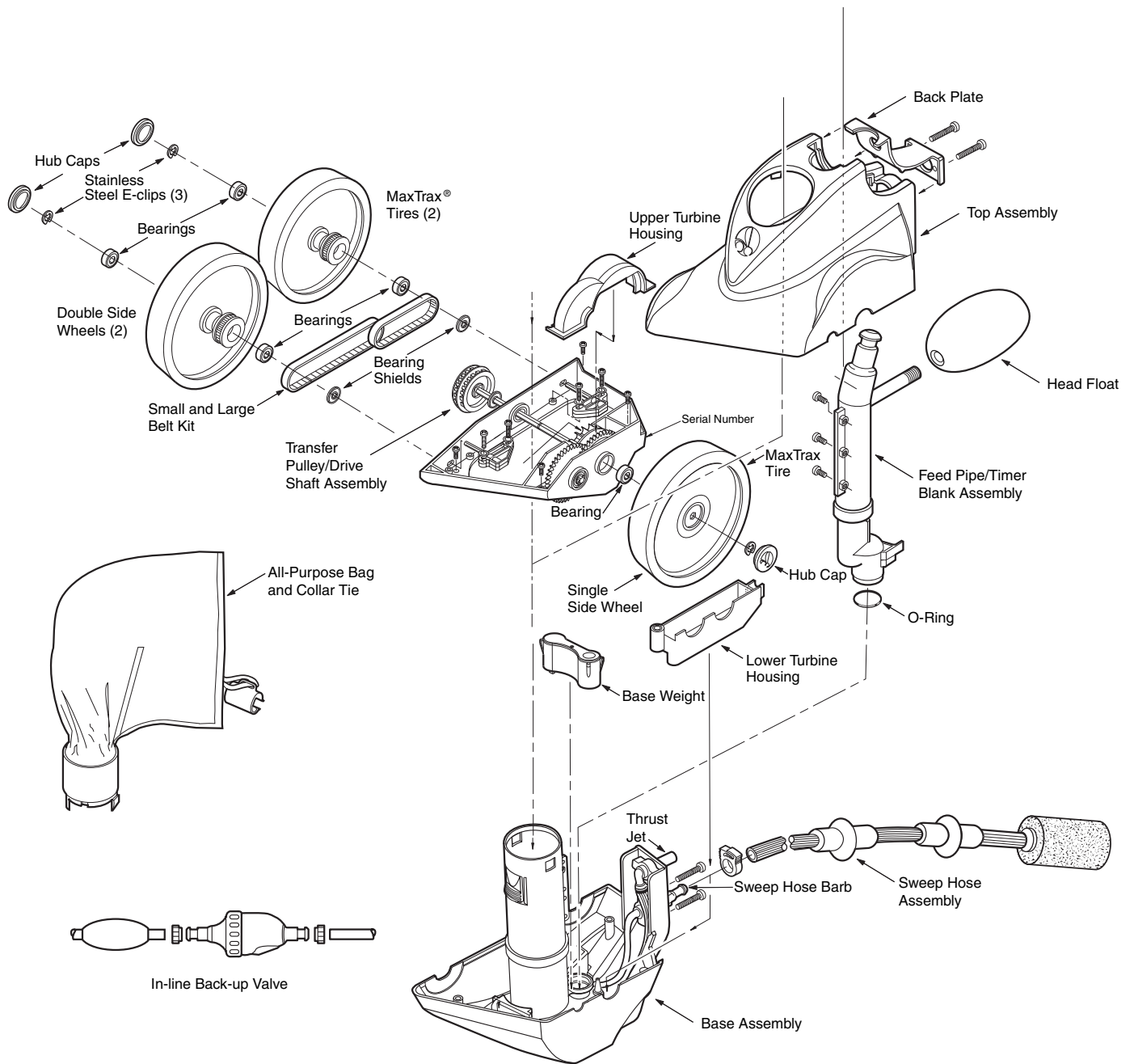

Polaris 380 Factory Rebuild Kit Limited Warranty

This limited warranty is extended to the original consumer purchaser of this Polaris 380 Rebuild Kit manufactured by Polaris Pool Systems, Inc., 2620 Commerce Way, California 92081-8438, USA.

Polaris warrants the parts in this kit to be free of defects in material and workmanship. We do not cover tires, bottom plates, belts, or bearings which have been worn out by use. These are normal replacement items. We do not cover damage caused by improper installation of the parts in the Rebuild Kit. If you have a question regarding your Polaris 380 Rebuild Kit or your Polaris 380 Automatic Swimming Pool Cleaner, please feel free to call or write us. Please provide the serial number, which can be located under the handle on the rear of the frame of your unit, when you contact us.

The Polaris 380 Factory Rebuild Kit is warranted for a period of one year from date of purchase with proof of purchase.

This limited warranty does not apply if the failure is caused or contributed to by any of the following: improper handling, improper usage, improper storage, winter freezing, abuse, improper installation, unsuitable application of the unit, improper maintenance, lack of reasonable and necessary maintenance, damage in transit or during installation, or damage from repairs/alterations made or attempted by anyone other than Polaris or one of its Authorized Service Centers. Polaris will repair or replace, at its option, a part proved to be defective within the warranty period and under the conditions of the warranty.

In order to make a claim under this warranty, the consumer must deliver or ship the unit or warranty parts freight prepaid to the nearest Polaris Authorized Service Center or return it freight prepaid (after proper authorization) to the plant of manufacture. Authorization to return a unit or parts to the plant of manufacture must be obtained from the Polaris Customer Service Department. Check with your dealer for the local procedure before exercising this warranty. If further directions or instructions should be required, contact the Customer Service Department at 1-800-822-7933 (USA and Canada only) or (760) 599-9600. Be sure you insure your shipments against loss or damage in transit.

Polaris is not responsible for the cost of removal of the unit or parts, damages during or due to removal, any other expenses incurred in shipping the unit or parts to or from the factory or its Authorized Service Centers, or damages during the installation of the repaired or replacement unit. The consumer must bear these expenses.

This warranty does not cover repair or replacement of a unit or part except at our plant of manufacture or Polaris Authorized Service Center. This warranty does not cover pattern removal, abrasion or markings on a vinyl liner.

THIS LIMITED WARRANTY IS IN LIEU OF ALL OTHER WARRANTIES, EXPRESS OR IMPLIED, INCLUDING THE IMPLIED WARRANTIES OF MERCHANTABILITY AND FITNESS FOR A PARTICULAR PURPOSE, AND ALL SUCH OTHER WARRANTIES ARE DISCLAIMED EXCEPT TO THE EXTENT ANY IMPLIED WARRANTY MAY BE IMPOSED BY STATE CONSUMER LAW. ANY SUCH IMPLIED WARRANTY IMPOSED BY STATE CONSUMER LAW IS LIMITED IN DURATION TO ONE (1) YEAR FROM DATE OF PURCHASE. IN NO EVENT SHALL POLARIS BE LIABLE FOR INCIDENTAL OR CONSEQUENTIAL DAMAGES OF ANY NATURE OR KIND OR FOR DAMAGES TO PERSONS OR PROPERTY, INCLUDING ANY DAMAGE RESULTING FROM THE USE OF THE POLARIS 380 AUTOMATIC SWIMMING POOL CLEANER WITH A SUBSTANDARD POOL CIRCULATION SYSTEM.

Some states do not allow limitations on how long an implied warranty lasts, or the exclusion or limitation of incidental or consequential damages, so the above limitations may not apply.

This limited warranty is valid only in the United States of America, Canada and Australia, and it does not apply to Polaris 380 Factory Rebuild Kits sold or installed in any other country.



2620 Commerce Way, Vista, CA 92081-8438 • 760-599-9600 • 1-800-822-7933 • www.polarispool.com